



**US Army Corps
of Engineers**

Vicksburg District
4155 Clay Street
Vicksburg, MS 39183-3435
www.mvk.usace.army.mil



Public Notice

APPLICATION NO.:	MVK-2017-247
EVALUATOR:	Mr. Andy Sanderson
PHONE NO.:	(601) 631-5083
E-MAIL:	Andy.Sanderson@usace.army.mil
DATE:	May 23, 2018
EXPIRATION DATE:	June 12, 2018

Interested parties are hereby notified that the U.S. Army Corps of Engineers, Vicksburg District, and the Arkansas Department of Environmental Quality, are considering an application for a Department of the Army permit and State water quality certification for the work described herein. Comments should be forwarded to the Vicksburg District, Attention: CEMVK-OD-F, at the above address, and the Arkansas Department of Environmental Quality, Post Office Box 8913, Little Rock, Arkansas 72219-8913, and must reach these offices by the cited expiration date.

Law Requiring a Permit: Section 404 of the Clean Water Act (33 U.S.C. 1344), which applies to discharges of dredged and / or fill material into waters of the United States.

Name of Applicant:
Mr. George Cleve Batte
GCB Land Development, LLC
3837 East Street
Texarkana, Arkansas 71854

Name of Agent:
Mr. Glen Spears
Spears Engineering Company
3605 Jefferson Avenue
Texarkana, Arkansas 71854

Location of Work: Section 24, T15S- R28W, Latitude 33.4357°N, Longitude -93.9517°W, within the Mill Creek-McKinney Bayou watershed of the McKinney-Posten Bayous Drainage Basin (8-digit USGS HUC: 11140201), Miller County, Arkansas.

Description of Work: (See enclosed map and drawings.)

The following descriptions of the proposed project and associated impacts are based upon information provided by the applicant.

The applicant is applying for an after-the-fact Department of the Army permit for the construction of a 4 acre pond within jurisdictional areas. The purpose of the project is to provide a recreational pond for a home site. The pond resulted in the fill of approximately 148 linear feet of intermittent stream for construction of the pond levee, inundation of approximately 1,102 linear feet of intermittent stream for the pond, and the culverting of approximately 30 linear feet of intermittent stream on the upstream end of the pond for a crossing. Approximately 132 cubic yards of fill was discharged into jurisdictional areas for the construction of the dam.

The spillway is constructed of three 36-inch culverts and one 24-inch culvert and was designed for a 100-year rainfall event. The levee is approximately 16-feet high by 450-feet long, with a top width of approximately 30-feet.

The vegetative communities within the project area are dominated by water oak, white ash, sweetgum, horse sugar, redbud, mockernut hickory, eastern baccharis, blackberry briar, Chinese privet, American beautyberry, Ohio buckeye, and cockspur hawthorn. Soil within the project site consists of Amy silt loam.

The applicant proposes to mitigate for the unavoidable loss of jurisdictional impacts through permittee-responsible mitigation.

Upon reviewing this notice, you should write to this office to provide your opinion of the impacts this work will have on the natural and human environment and address any mitigation you believe is necessary to offset these impacts. Other comments are welcome, but the above information will further our review of the applicant's plan as proposed. Comments of a general nature are not as helpful as those specific to the impacts of the subject project.

State Water Quality Permit: The State Pollution Control Agency must certify that the described work will comply with the State's water quality standards and effluent limitations before a Corps permit is issued.

Cultural Resources: The Regulatory Archaeologist has reviewed the latest published version of the National Register of Historic Places, state lists of properties determined eligible, and other sources of information. The following is current knowledge of the presence or absence of historic properties and the effects of the proposed undertaking upon these properties: An historic properties investigation has been conducted within the permit area. No sites determined eligible for or listed on the National Register of Historic Places are within the permit area or affected area.

Endangered Species: Our initial finding is that the proposed work would have no effect on the following endangered species or their critical habitats: Piping plover. This proposal is being coordinated with the U.S. Fish and Wildlife Service, and any comments regarding endangered species or their critical habitat would be addressed in our evaluation of the described work.

Floodplain: In accordance with 44 CFR Part 60 (Floodplain Management and Use), participating communities are required to review all proposed development to determine if a floodplain development permit is required. Floodplain administrators should review the proposed development described in this public notice and apprise this office of any flood plain development permit requirements. The project is not located within the 100 year floodplain.

Evaluation Factors: The decision whether or not to issue a permit will be based upon an evaluation of the probable impact of the proposed activity on the public interest. That decision will reflect the national concern for both protection and utilization of important resources. The benefits which may be expected to accrue from the proposal must be balanced against its expected adverse effects. All factors which may be relevant to the proposal will be considered; among these are conservation, economics, aesthetics, general environmental concerns, historic values, fish and wildlife values, flood damage prevention, land use classification, navigation, recreation, water supply, water quality, energy needs, safety, food requirements and, in general, the needs and welfare of the people. Evaluation of the proposed activity will include application of the guidelines published by the Environmental Protection Agency under authority of Section 404(b) of the Clean Water Act.

Public Involvement: The purpose of this notice is to solicit comments from the public; Federal, State, and local agencies and officials; Indian Tribes; and other interested parties. These comments will be used to evaluate the impacts of this project. All comments will be considered and used to help determine whether to issue the permit, deny the permit, or issue the permit with conditions, and to help us determine the amount and type of mitigation necessary. This information will be used in our Environmental Assessment or Impact Statement. Comments are also used to determine the need for a public hearing.

Opportunity for a Public Hearing: Any person may make a written request for a public hearing to consider this permit application. This request must be submitted by the public notice expiration date and must clearly state why a hearing is necessary. Failure of any agency or individual to comment on this notice will be interpreted to mean that there is no objection to the proposed work. Please bring this announcement to the attention of anyone you know who might be interested in this matter.

Notification of Final Permit Actions: Each month, the final permit actions from the preceding month are published on the Vicksburg District Regulatory web page. To access this information, you may follow the link from the Regulatory web page, <http://www.mvk.usace.army.mil/Missions/Regulatory.aspx>.

Thomas A. McCabe
Thomas A. McCabe
Chief, Evaluation Section
Regulatory Branch

MR. GEORGE CLEVE BATTE
 GCB LAND DEVELOPMENT LLC
 CEMVK-OD-FE AS-MVK-2017-247

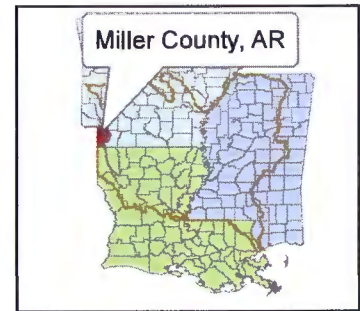

12 September 2017
MVK-2017-247
 Jurisdictional Determination
 Mosbey Pond
 Miller County, Arkansas
**Preliminary
 Jurisdictional Determination**
 Prepared by
 Arel Simpson



US Army Corps of Engineers.

Regulatory Branch
 Enforcement Section

0 100 200 400 Feet

Enclosure 1

Legend	
	Mosbey Project Boundary (40.28 Acs.)
	Project Boundary (41.43 Acs.)
	Culverted Crossing (30 L.F.)
	Intermittent Stream (148 L.F. Filled)
	Intermittent Streams (1,102 L.F. Inundated)
	Intermittent Stream (782 L.F. Undisturbed)
	Access Road
	Dam
	Pool Stage Mosbey Pond (3.93 Acs.)

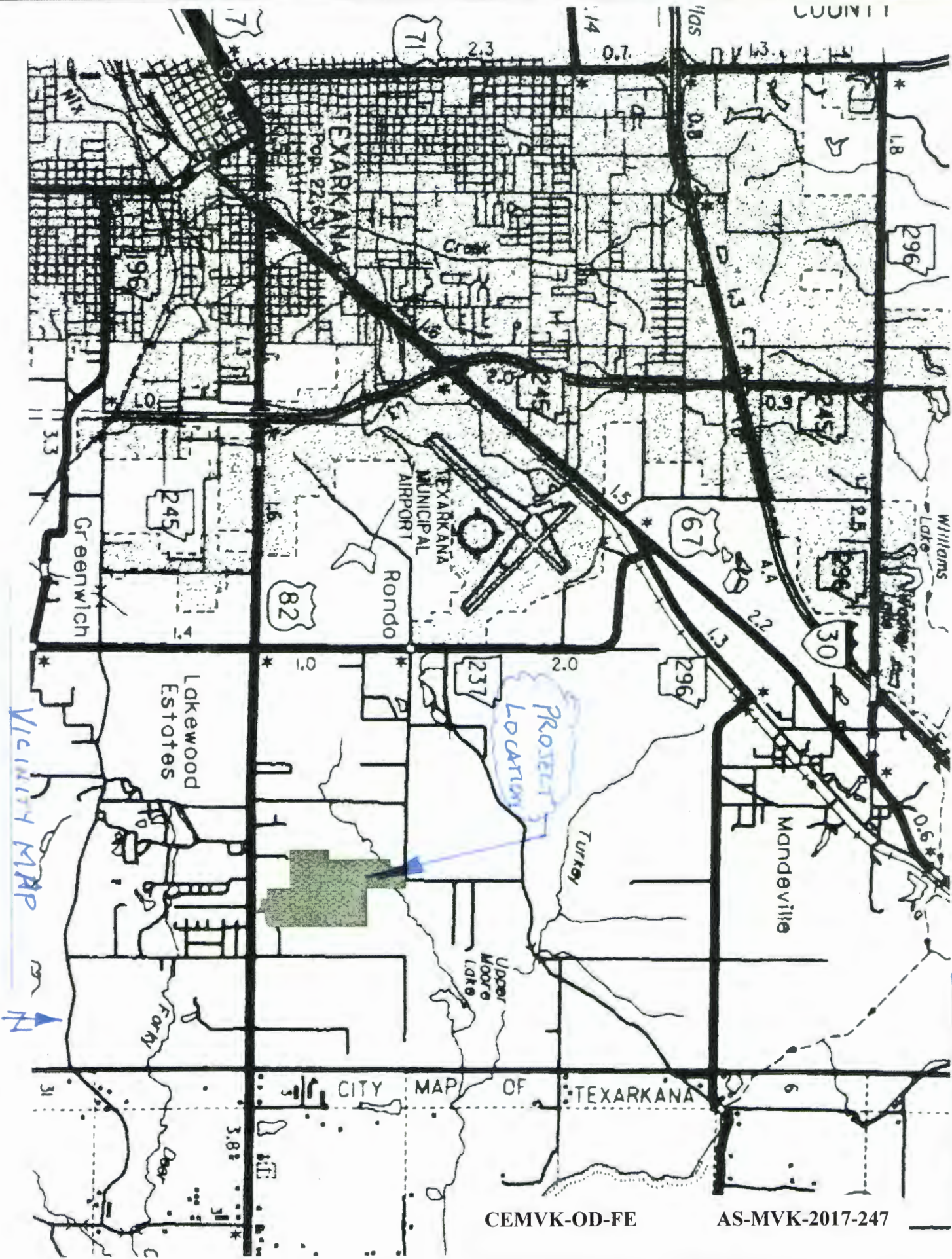

VICINITY MAP

ATTACHMENT No. 2

CEMVK-OD-FE

AS-MVK-2017-247

MR. GEORGE CLEVE BATTE
 GCB LAND DEVELOPMENT LLC

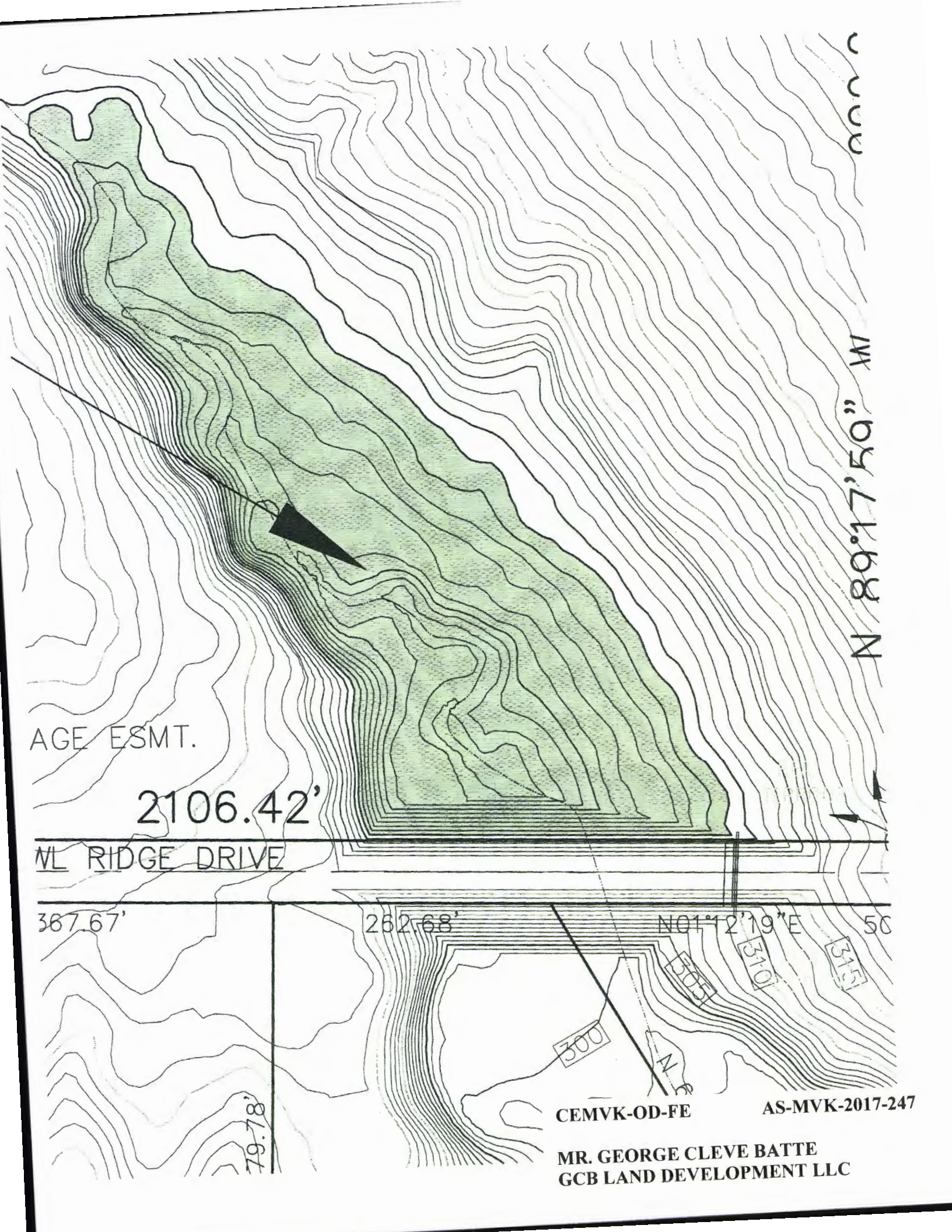

N 89°17'59" W

AGE ESMT.

2106.42'

ML RIDGE DRIVE

387.67'

262.68'

N 01°12'19" E

50

79.78'

CEMVK-OD-FE

AS-MVK-2017-247

MR. GEORGE CLEVE BATTE
GCB LAND DEVELOPMENT LLC

MOSBEY POND:

AVG. CREEK SECTION:

X-SECT AREA = 22.5 ft^2

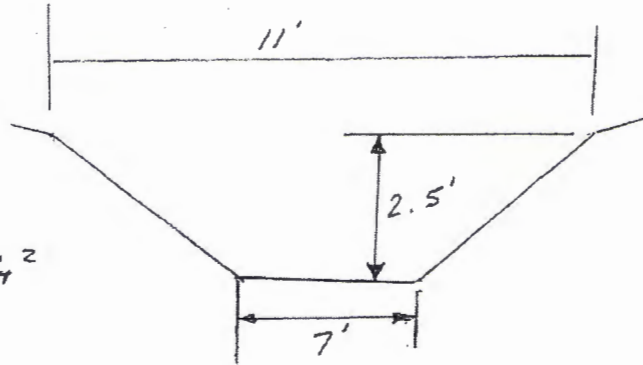

PROPOSED DAM:

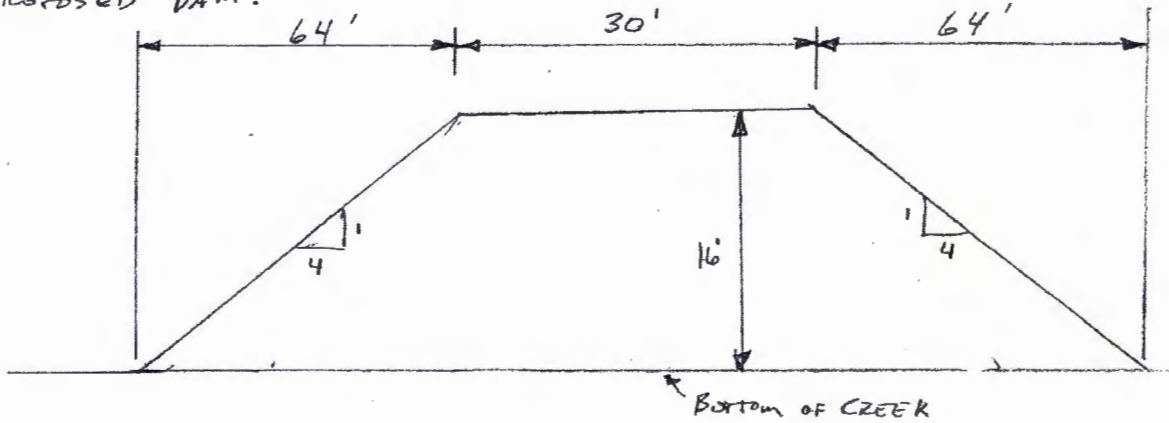

TOTAL LENGTH OF CREEK FILLED = 158'

VOLUME = $(22.5 \text{ ft}^2) (158') \left(\frac{1 \text{ CY}}{27 \text{ ft}^3}\right) = 132 \text{ CY}$

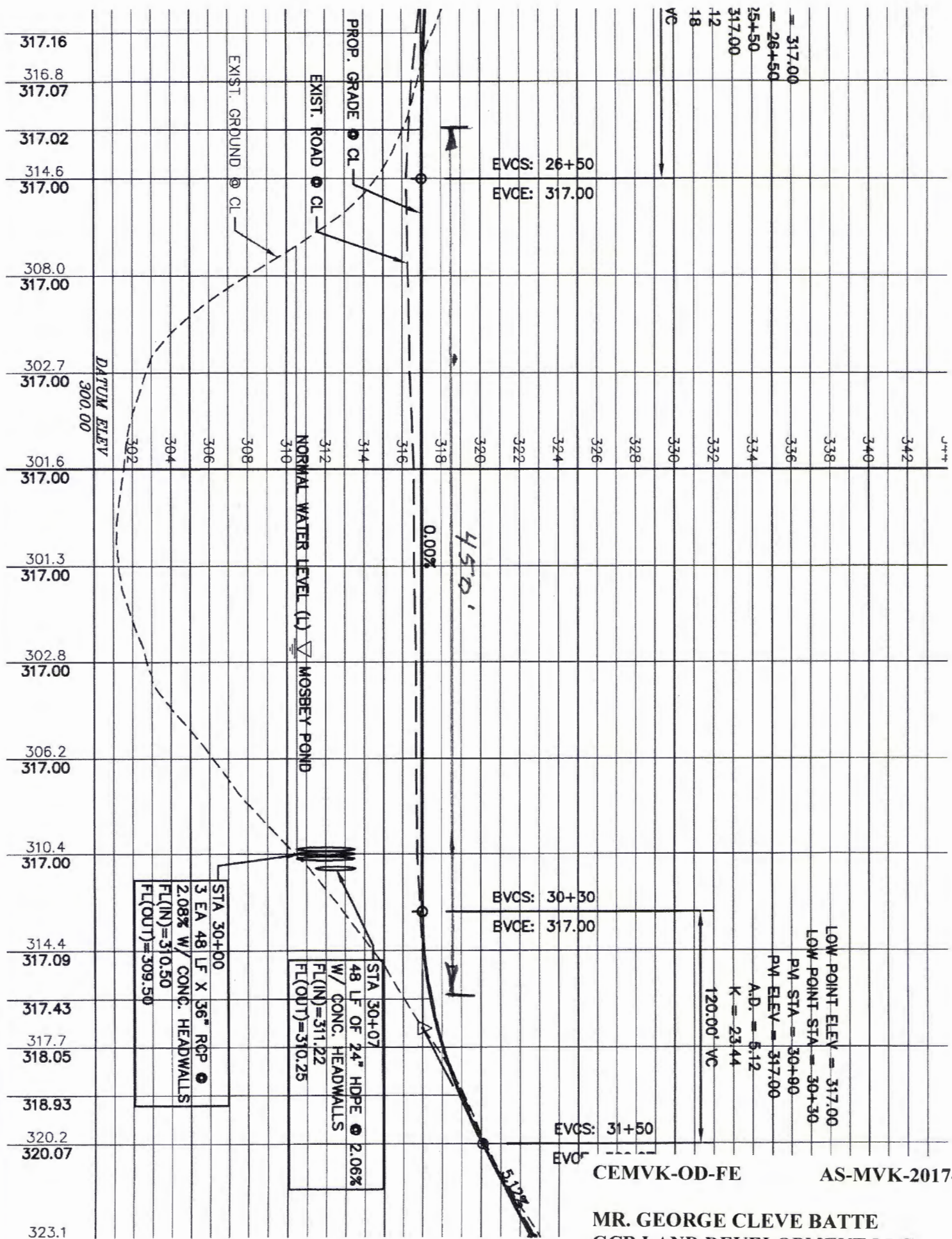

CEMVK-OD-FE AS-MVK-2017-247

MR. GEORGE CLEVE BATTE
 GCB LAND DEVELOPMENT LLC